

## Size and Load-Carrying Considerations

### Load-Carrying Capacity

Many tire problems result from insufficient attention to tire pressures the tables in this guide list the recommended inflation pressures for the O.E. tires for the vehicle.

For the replacement tire, use the inflation pressure shown on the O.E. tire (unless otherwise indicated in the tables) when making the following changes.

- P-Series tires replaced with P-Series tires.
- European Metric tires replaced with European Metric tires.
- P-Series tires replaced with Metric tires.
- In all cases, check the load inflation table for the replacement tire size to ensure the inflation pressure for the replacement tire size to ensure the inflation pressure you use is sufficient for the vehicle axle load.

***NOTE:** P-Series tires and European Metric tires have different load inflation tables and do not carry equal loads at equal pressures. Refer to recommended fitment(s) for a specific vehicle application in the fitment section of this guide.*

**IMPORTANT** – Provide your customers with a decal containing recommended pressure for their tires and advise them that:

- Inflation pressure should be checked frequently at least once each month, and always before a long-distance trip.
- Pressures should be checked when tires are cold, before they have been driven on. Driving even a short distance causes tires to heat up and air pressures to increase.
- Failure to maintain the correct inflation pressure is dangerous. It can also cause:
  - Tire damage
  - Rapid and/or irregular tread wear
  - Improper vehicle handling
  - An unacceptably harsh ride
- A seriously under-inflated tire driven even a short distance may sustain irreparable damage.
- Driving on under-inflated tires builds up excessive heat that could result in sudden tire destruction.



**Warning:** Serious or fatal injury may result from under-inflation or overloading.

### Proper Inflation Pressures

One of the most important yet simple services you can offer to improve your customers' tire performance is to properly inflate their tires to suit their needs. Inflation pressure affects the tread profile shape and the contact pressure across the tread surface. Changing the inflation pressure alters how the tire will function on your customer's vehicle.

The pressure should never be below the minimum listed on the vehicle placard nor above the maximum branded on the sidewall of a specific tire in normal driving conditions.

The best recommendation is to use the inflation pressure specified on the vehicle placard. The O.E. vehicle manufacturer has determined this pressure is optimal for load, ride handling, rolling resistance and treadwear performance

The customer may request inflation pressures different from the vehicle placard. You must advise the customer to the advantages/disadvantages of the deviation.

Higher inflation pressure increases the crown radius of the tire, reducing the contact pressure at the shoulder and giving a slightly smaller footprint.

In general, performance improvements of higher inflation pressure include steering response, fuel economy, hydroplaning resistance and treadwear (less shoulder wear)

Lower inflation pressure decreases (flattens) the crown radius of the tire, increasing the contact pressure at the shoulder. In general, performance improvements of lower inflation pressure include smoother ride, snow traction, bruise resistance and less strain to suspension system components.

For the everyday driver, it is imperative to make sure the tire pressure is adequate to support the vehicle load. The vehicle's placard will indicate the proper inflation pressures/load index, and the MAST Fitment Guide lists proper inflation/load capacity to assist you.

Make sure to check the tire's sidewall or the vehicle placard for the specified inflation pressures for the tires. Never exceed the maximum inflation pressure branded on the sidewall of the tire.

A rule of thumb to remember is all passenger and light truck tires, for highway use, should never be inflated less than 20 psi. For any 16.5" rim diameter light truck tires, the minimum inflation pressure branded on the sidewall of the tire.

A rule of thumb to remember is all passenger and light truck tires, for highway use, should never be inflated less than 20 psi. For any 16.5" rim diameter light truck tires, the minimum inflation pressure is 30 psi. Pressure lower than those specified can only be used off-road, when speeds are lower than 15mph. However, ensure the load carrying capacity is still adequate to avoid tire failure. When the tires are returned to highway use, they must be re-inflated to at least the minimum specified inflation pressures to avoid handling impairment.

### **Competitive Inflation Recommendations**

While everyday driving requires inflation pressures close to the manufacturer's recommendations, competitive situations often require higher or lower pressures than usual. Parameters such as wear and ride comfort are much less important than cornering, traction or steering response.

Autocross and road race drivers often use pressures of 45-50 psi or higher to improve steering response. They might also modify the understeer/oversteer characteristics of the vehicle by using vastly different pressures front to rear, especially in front-wheel drive or rear-engine vehicles.

Conversely, off-road driving conditions call for lower inflation pressures, which offer better bruise resistance and more flexibility in the sidewalls. In rocky, uneven terrain, impact absorption takes precedence over quicker steering response. One disadvantage is a higher probability of pushing the tire off the rim with extremely low pressures.

The optimum inflation pressures vary widely based on type of competition, vehicle, track layout, surface, driving style, weather conditions, etc. There are some basic rules of thumb, such as higher front pressures reduce understeer and higher rear pressures reduce oversteer, characteristics of the vehicle by using vastly different pressures front to rear, especially in front-wheel drive or rear-engine vehicles.

The optimum inflation pressures vary widely based on the type of competition, vehicle, track layout, surface, driving style, weather conditions, etc. There are some basic rules of thumb, such as higher front pressures reduce understeer and higher rear pressures reduce oversteer, but these rules are not always accurate due to the effect of all the variables.

Due to modern tire constructions, the chalking of the tire shoulder to determine proper inflation pressures for track and autocross by looking at tire rollover is no longer accurate. The only truly accurate way to determine the optimum inflation pressure is to take tread temperatures with a pyrometer. The goal is to obtain even tread temperatures across the tread surface (inside shoulder/center/outside shoulder). The temperatures should be taken immediately after coming off the track.

On street cars, you will probably not be able to obtain an even tire temperature distribution due to the suspension geometry. In this case, try to get a linear temperature distribution such as 225/200/175 degrees outside/center/inside temperature spread.

A hotter outside and cool center and inside mean you need to increase pressure. A hotter center temperature needs lower pressure. Add or subtract pressure in 2-3 psi increments.

If the customer's vehicle will be returning to highway use after the competitive event, be certain that the inflation pressures are readjusted to manufacturer's specifications.

Be sure to check your resources to assure you are advising your customer properly. Everyday and competitive driving situations require very different inflation pressures, and each customer needs to be treated individually, not with a standard recommendation.

Feel free to call your MAST Sales Representative if you need assistance in an unusual inflation situation.

### **Minimum Inflation Pressures**

Lower inflation pressures for improved flotation are permitted **ONLY** if the tire maintains adequate load-carrying capacity at the lower pressure. **DO NOT** go below these following minimums:

MINIMUM PRESSURE	TYPES OF TIRES
30 psi	16.5" Rim Diameter Light Truck Tires
20 psi	Passenger and Light Truck tires used on the highway

**NOTE:** Pressures lower than 20 psi may be used off the road when speeds are less than 15mph and when the tire has adequate load-carrying capacity at the lower pressures. (16.5" LT tires may not be used below 30 psi)

 **Warning:** Tires must be reinflated to the minimum pressures shown for highway service. Failure to reinflate tires for highway use will seriously impair vehicle handling and possibly result in tire failure.

## Replacing Speed-Rated Tires

When replacing speed-radial tires, you must use replacement tires with ratings equal to or greater than those of the O.E. tires if the speed capability of the vehicle is to be maintained. If the O.E. tires are not speed-rated, they can be replaced with speed-rated tires of the appropriate size and inflation pressure. It's important to note that applying tires with a higher speed rating than that suggested by the vehicle manufacturer will not increase the speed capability of the vehicle.

This guide does NOT indicate speed ratings for recommended replacement tires. When replacing speed rated tires, we suggest that you follow the guidelines written in the Rubber Manufacturers Association Tire Information Service Bulletin for passenger tires: (Volume 34, Number 1, January 1993 for light truck tires): when replacement of tires is desired, consult the vehicle placard (normally located on the door frame or glove box door) or Owner's Manual for correct size, construction, and speed rating. If the tires shown on the vehicle placard do not have speed ratings, speed-rated tires may be mounted, if desired.

When the placard tire size nomenclature contains a speed symbol (for example P215/60R15 93V) the replacement tire must have the same or higher speed rating **IF THE SPEED CAPABILITY OF THE VEHICLE IS TO BE MAINTAINED.**

If the replacement tire is not speed-rated, the speed capability of the vehicle is limited by the speed capability of the replacement tire.

 **Warning:** When a performance vehicle customer requests a replacement tire with a lesser speed rating than the O.E. tire, you **MUST** advise the customer that the handling of the vehicle may be different and that its maximum speed capability is limited to that of the lowest speed-rated tire on the vehicle. Refer to the vehicle owner's manual to identify any tire speed rating restriction that could affect the operation of the vehicle. We do not endorse the operation of any vehicle in an unsafe or unlawful manner since property damage, serious injury or death may occur.

## **PLUS 1 AND PLUS 2 SIZING**

Plus sizing is a concept designed to achieve enhanced vehicle performance over a base original equipment fitment. There are two main benefits for “Plusing up”. First for many customers it is strictly cosmetic. A larger wheel simply looks better. Secondly, the wider section widths and lower profiles realized from the Plus concept yield a wider footprint that increases the vehicle’s steering response and overall cornering force. As the example in the chart indicates, increasing rim diameter, rim width and tire section width while decreasing aspect ratio gives the customer a higher level of handling with no change in gearing or speedometer accuracy.

In crating Plus sizing fitments, there are several basic principles that must be understood and satisfied.

1. Determine the diameter of the wheel desired by the customer. This will be based on appearance or performance.
2. With the wheel diameter from Step 1, select a lower aspect ratio tire with wider section width, but maintain overall diameter equal to original tire size.
3. Insure selected tire has equal or greater load carrying capability to the original equipment fitment.
4. Choose rim width within acceptable rim width range for the selected tire size.
5. When mounted, verify adequate wheel well and suspension component clearance.

Historically, the idea of keeping the same overall tire/wheel diameter was related only to maintaining the same gearing and accurate speedometer readings. These two issues are still important, but there are even more critical reasons for maintaining the same overall diameter in modern vehicles.

First of all, virtually all currently marketed vehicles include anti-lock braking systems or ABS, ABS systems work by monitoring relative wheel speeds. Large changes in the overall diameter of the tire/wheel assemblies can alter the effectiveness of certain ABS systems.

Many vehicles also have traction control systems as well as ABS. Once again, changes in diameter can have an effect on these systems. In conjunction with ABS and traction control, stability control systems are also becoming more common. These systems monitor cornering behavior, and selectively brake certain wheels to reduce understeer or oversteer helping the driver more easily maintain control of the vehicle.



Once again, it is important to maintain the overall diameter of the tire at or near the O.E. fitment.

Two other relatively new issues can also be affected by changing tire diameter. One, called OBD II; is related to vehicle emissions. The other has to do with the fact that many of today’s modern vehicles have electronically controlled automatic transmissions. These transmissions use vehicle speed, as well as other inputs, to determine shift points. If vastly different diameter tires are fitted, not only will the speedometer be inaccurate, but also the transmission-shifting pattern will be altered resulting in less than optimum performance.

Make sure the tire/wheel combination fits without any clearance problems. Check for clearance between the wheel, brake, and suspension components as well as the tire and wheel well areas. Clearances also need to be checked on the road during hard cornering and tight turning.

A knowledge of custom wheels will further help you in achieving superior performance for your “Plus” customers. Remember that one of your customers’ biggest advantages in moving up to Plus 1 and Plus 2 tires is the large variety of MAST performance tires in 70, 65, 60, 55, 50, 45, 40, 35 and 30 series sizes from which to choose.

The chart below is an example that illustrates the effectiveness of Plus 1 and Plus 2 options.

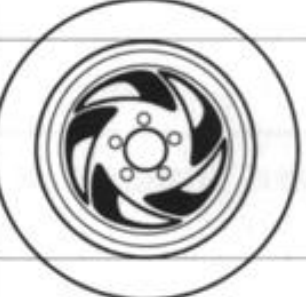
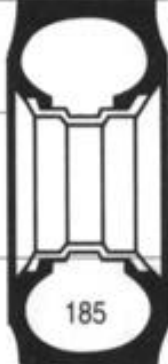
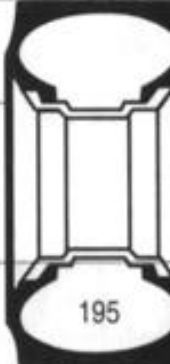
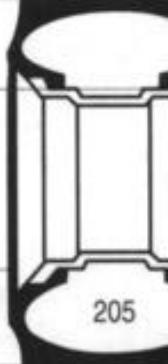
	PLUS 0	PLUS 1	PLUS 2
	185/70R13	195/60R14	205/50R15
			
TIRE DIAMETER	23.22"	23.22"	23.11"
TIRE LOAD CAPACITY	985 lbs.	985 lbs.	985 lbs.
INFLATION FRONT/REAR	28/28 psi.	28/28 psi	28/28 psi
SECTION WIDTH	7.44"	7.91"	8.43"
			
	185	195	205

### Passenger Tires and High-Speed Driving

For high-speed driving, additional inflation pressure and possible reduced tire loading and/or up sizing are required. The following guidelines are taken from the European Tyre and Rim Technical Organization (ETROTO) Standards manual. Note that tire up sizing may be necessary to achieve the proper load-carrying capacity at the reduced inflation.

As an example: When using V-speed rated tires, for speeds up to 160 Km/h (100mph), standard inflation pressure must be applied; for speeds between 160 km/h (100 mph) and 210 km/h (130 mph) increased inflation pressure is required, and the load-carrying capacity of the tire is reduced which may require up-sizing. The following table shows the inflation and load-carrying capacity adjustments required at specified speeds.



Never exceed the maximum inflation pressure molded on the tire sidewall. Explosive failure may result leading to property damage, serious injury, or death.

## High-Speed Pressure/Load Capacity Adjustments ETRTO Recommendations

Speed Ratings Up Through "V" Rating

"ZR", "W" Rating

"ZR", "Y" Rating

Speed Ratings Up Through "V" Rating					"ZR", "W" Rating					"ZR", "Y" Rating				
Vehicle Top Speed		Pressure Increase		Tire Load Capacity (%max*)	Vehicle Top Speed		Pressure Increase		Tire Load Capacity W	Vehicle Top Speed		Pressure Increase		Tire Load Capacity Y
km/h	mph	bar	psi		km/h	mph	bar	psi		km/h	mph	bar	psi	
160	100	0	0	100%	190	118	0	0	100%	220	136	0	0	100%
170	106	.06	1	100%	200	124	.1	1.5	100%	230	143	.1	1.5	100%
180	112	.12	2	100%	210	130	.2	3.0	100%	240	149	.2	3.0	100%
190	118	.18	3	100%	220	136	.3	4.5	100%	250	155	.3	4.5	100%
200	124	.24	4	100%	230	143	.4	6.0	100%	260	161	.4	6.0	100%
210	130	.30	5	100%	240	149	.5	7.5	100%	270	168	.5	7.5	100%
220	136	.30	5	97%	250	155	.5	7.5	95%	280	174	.5	7.5	95%
230	143	.30	5	94%	260	161	.5	7.5	90%	290	180	.5	7.5	90%
240	149	.30	5	91%	270	168	.5	7.5	85%	300	186	.5	7.5	85%

\*% of max. branded on tire

### Notes:

- Never exceed the maximum inflation pressure branded on the sidewall.
- For ZR tires with speeds above 270 km/h (168 mph), consult the vehicle manufacturer and the dealer for speed limitations.
- We neither recommend nor endorse exceeding the lawful speed limits on public roads and highways.